

CYRUS 2014 Team Description

Shahid Beheshti University, Iran

Eslam Nazemi¹, Sina Raessi¹, Javad Amiryan³, Abolfazl JafarzadehPour¹, Sina Mohammadzadeh¹, Amin Nikoukar², Mahdi Aali¹, Nariman Eskandari¹

¹Department of Electrical and Computer Engineering of Shahid Beheshti University

²Department of and Architecture and Urban Planning of Shahid Beheshti University

³Department of Computer Engineering of Sharif University of Technology

<http://www.robocup.sbu.ac.ir/>

Abstract. In this paper the current state of Cyrus robotic team is described. Our mechanical designs have provided sufficient speed and accuracy for robots while electrical boards are redesigned to obtain more reliability. On the other hand software system has been fully reconstructed and our last Java-based code has been completely substituted for a new Qt-based one. Moreover a *robotic team manager application* has been designed and developed for Android 4 which can be run on tablet computers and bring some useful tools for team coaches.

1 Introduction

We've gained many experiences by participating in 5 national and international tournaments and each year many related technologies have been imported to the team. In the last competition (AUT CUP 2013) we have completely tested our hardware in both mechanical and electronic parts. This year as previous years, some improvements are applied in both hardware and software systems. The mechanical parts are redesigned in order to achieve more accurate robots while some changes to electrical boards have been done to get more reliability and performance. In the following section, the changes in mechanical system will be mentioned. Afterward new FPGA-based main board will be proposed. In section 4, new software architecture would be surveyed and also some explanations about our robotic team manager application will be presented.

2 Mechanical Design

In new mechanical design we've focused on some criterions which will be discussed here. Since we still use brushed DC motors which have lower speed and power rather than BLDC ones, we decided to change the angle between the robot axels i.e. we increased the angle between rear wheels to 104° to achieve more velocity in forward

and backward directions which helps to reduce the travel time. Secondly, by testing the position of different objects in the robot a suitable centroid was obtained. Besides new omni-directional wheels are built with larger sub-wheels which make the robot movement more precise.

Each robot is 178mm in diameter and 138mm in height and at most covers 20% of the ball. A view of mechanical system is shown in Figure 1.

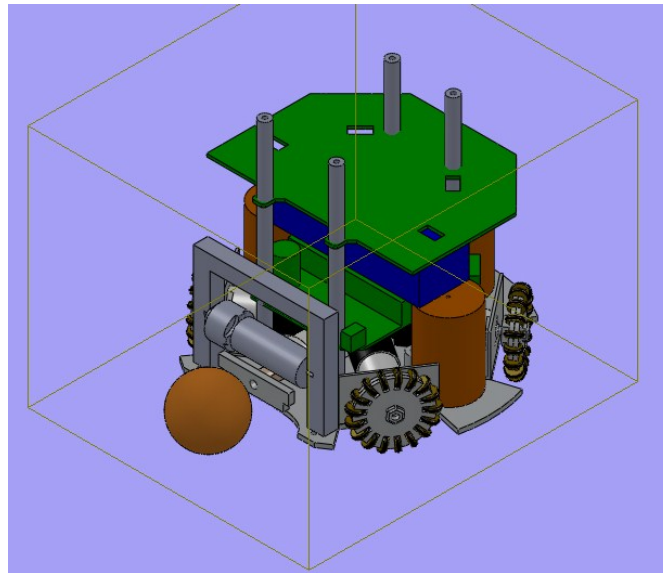

Fig. 1. Robot Mechanical Design

3 Electrical design

This year we focused on reliability of the boards and also the capability of precise control of driving motors. So a new FPGA-based main board is designed and implemented. Furthermore the kicker board which was one of our major troubles was redesigned and a more robust board one increases system provides the controlling signals to the driving system and kicker module and consists of two separate boards called the main board and the kicker board, respectively. The main reason for separating these parts is to reduce the effect of electrical noise caused by boosting and kicking functions of the kicker board on the other parts.

3.1 Main Board

The main board has the duty of receiving data via wireless module, analyzing it, and controlling the motors. It also sends commands to the kicker board as to determine the time and power of kicking. Our redesign of robots from 2009 to 2013 involves a

completely new electrical subsystem. In 2010 we utilized ATMEGA16 MCU from AVR family microcontrollers. In 2011 we replaced our main microcontroller with ARM7 family - AT91SMA7X - and then in 2012 and 2013 Iran Open competition we designed our main boards based on ARM LPC1768 which provides many better features. 100MHz clock speed in comparison to our last 50MHz clock speed and a cortex-M3 arm processor provides faster PI calculations for the controller division. In this case one of the board's advantages is the ability of easy programming which can be done by an onboard USB 2.0 port. Moreover in new design we have implemented the ability of programming the board wirelessly via our Xbee modules more easily. We have also changed our motor driving system from the old L298 IC ones to the MOSFET bridges ones which provide more efficiency and reliability. This new design has the ability to drive both brushed DC and BLDC motors.

For Robocop 2013 we decide to utilize FPGA Spartan III family - Xilinx XC3S400 chip - as the only processor on the main board to generate all control signals for all parts such as wireless communication, kicking force, driving and so on. This chip is chosen because of its low power consumption, its high number of available pins and its huge logic gate numbers in comparison with other similar products. The Xilinx Spartan III, with its IP core provides significantly faster computation, when compared to the previous robot MCUs; besides Using FPGA, in addition of real-time benefits, would considerably reduce the number of components on the board and makes the debugging procedure much easier. Figure 2 represents the relation between FPGA and other units:

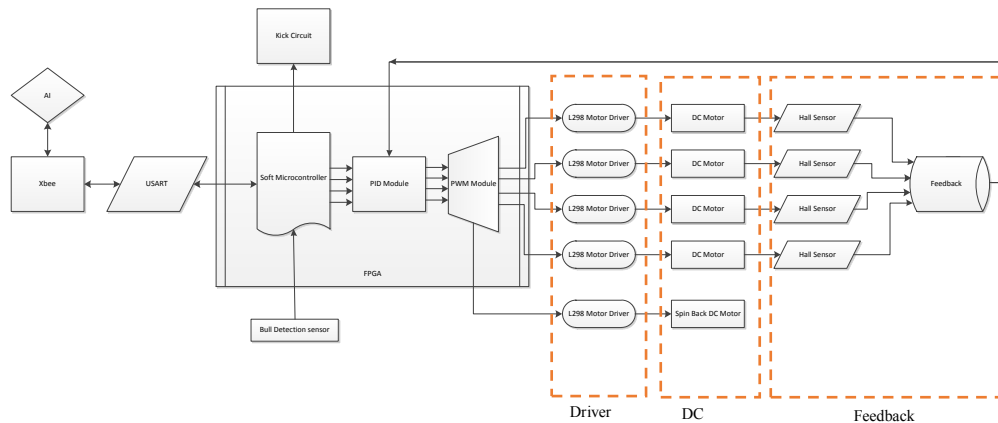

Fig. 2. New FPGA-based Electrical Design

3.1.1 Motor Driver

The new driver system utilizes MOSFET bridges which can support both brushed DC and BLDC motors in order to use our new boards with our old brushed and new designed robots with brushless motors.

3.2 Kicker Board

We have used advanced boost circuit topology with a current and voltage feedback on our robot's kicker board. The booster charges three paralleled 1600 μF -250 V capacitors up to 240 Volts using a voltage feedback to measure the capacitors' voltage and a current feedback to adjust the switching duty cycle. The change that has been made here is that we increased the PWM frequency in order to have a higher efficiency and reduce the loss of energy in inductors. We also used opto-couplers in order to isolate the control and power parts.

4 Software System

The software system is totally changed and new codes are rewritten in C++ language using Qt Framework while last software was developed with Java. The main idea for this transform is to increase software performance and still maintain the ability of running the code on any platform. The decision making system has been designed using STP Architecture. In Fig. 3 a view of software system is shown. The whole system is split to two separate parts for increasing modularity. The AI system would be run on the host computer and visualizer would be run on another one. Visualizer is a GUI application which provides the same tools of Soccer Robot Team Manager App. This software is also developed using Qt Designer and connects to Host PC via TCP/IP protocol while receives data from it using UDP protocol.

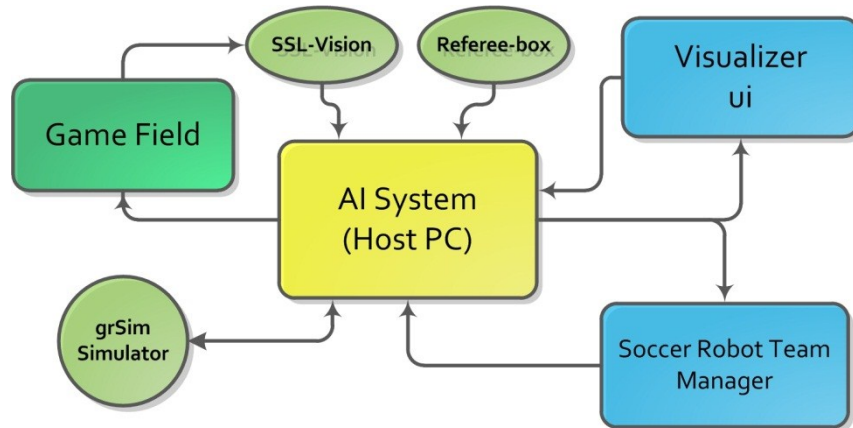

Fig. 3. Block Diagram of Software System

4.1 Decision Maker

As mentioned before, this system is designed according to STP Architecture which is proposed by CMDragons [2]. In the head of this system there are two UDP sockets to make connection with vision and referee systems. After filtering the vision data, with Kalman filter, the World Model will be updated. As can be seen in Figure 3 in the test mode the vision data is captured from grSim [4]. This simulator is capable of generating vision data and sending it with the same format used by ssl-vision [3]. Moreover an optional additive Gaussian noise is considered which may bring the ability of testing the tracking system.

For task allocation, we have made a play library which is available in script file. The decision maker output determines a skill and a set of its parameters for each robot. The skills like `go_to_point`, `receive_pass` and so on might be the output of this system. The parameters are whether numerical or Boolean according to the skill. For implementation of path-planner module, the well-known RRT algorithm has been used.

After calculating the path and desired velocity for each robot an innovative module has the duty of generating motor velocities.

4.2 Calculating Motor Velocities

Experiences show that, the main issue in robot navigation is that the mechanical elements are not ideal i.e. the asymmetric forces between the robot wheels and ground result in imprecise movement of robot. For this problem we have proposed a new algorithm in which the mechanical system is assumed as a deterministic but predictable system. So a Takagi-Sugeno fuzzy method is used to estimate the effect of each motor on robot motion. For example in forward direction the plot is like Fig. 4. The different slopes for 4 lines show that the motors have not identical influence on robot movement in this special direction.

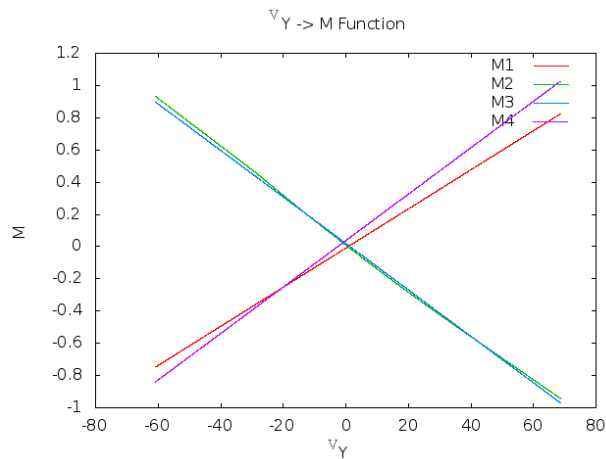

Fig. 4. Relation between Motor velocities and V_y , when $V_x=wz=0$

4.3 Soccer Robot Team Manager Application

It is obvious that during a game some interaction between the decision maker computer and the team coach for debugging is inevitable. Although it is not allowed to team members to handle the computer when game is running but in time-outs and halftime it is allowed. Moreover sometimes it is desired for team members to see what decision the system is making e.g. what path a robot decided to go through. Therefore many teams use an individual Graphic Interface to perform such these works. This year we developed an android application which can help a team coach. Some of its major features are:

- Watch live game on a tablet computer showing score, time, ...
- Detecting fouls in the game like double defender, ball-speed, ...
- Monitoring the decision maker output
- Redefining team strategies

In Figure 5 a screenshot of this application is shown.



Fig. 5. Soccer Robot Team Manager Application Screenshot

4.4 Motion Planner

In the new presented motion planner, a couple of planning algorithms are used to achieve a better performance in the quality of the robot paths and to reduce the planning time. A potential field as primary algorithm is responsible for producing plans in every situation, but if this planner trapped in local minima and failed to reach the target, the secondary planner would compensate. The advantage of this method is to produce optimal and stable plans as fast as possible in the most of the situations in

the game and doesn't have disadvantages of reactive planners. We chose RRT method for the secondary planner, which is a very fast algorithm and doesn't need to search entire the field to make a solution. In the following figure the results of the hybrid method is depicted.

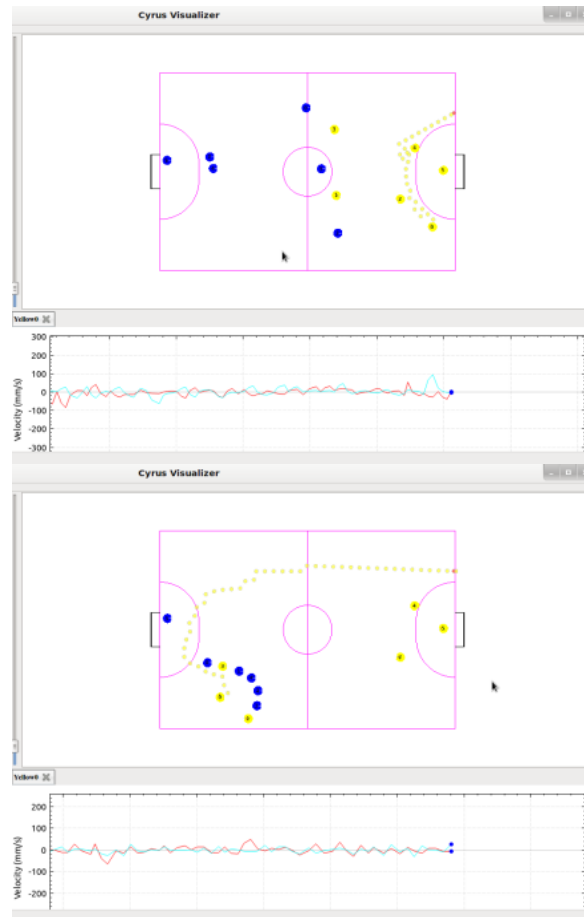

Fig. 6. Hybrid Motion Planner, up: the potential field plan, bottom: the plan generated by RRT

References

1. Amiryan, Javad, Sina Raeessi, Mohammad Moallemi, Mostafa Nazari, Abolfazl JafarzadehPour, Sina Mohammadzadeh, Amin Nikoukar, Mahdi Aali, and Nariman Eskandari. "CYRUS 2013 Team Description."
2. Browning, Brett, James Bruce, Michael Bowling, and Manuela Veloso. "STP: Skills, tactics, and plays for multi-robot control in adversarial environments." Proceedings of the Institution

of Mechanical Engineers, Part I: Journal of Systems and Control Engineering 219, no. 1 (2005): 33-52.

3. Nazari, Mostafa, Javad Amiryan, and Eslam Nazemi. "Improvement of robot navigation using fuzzy method." AI & Robotics and 5th RoboCup Iran Open International Symposium (RIOS), 2013 3rd Joint Conference of. IEEE, 2013.